

Boxes in Perspective

The line represents the corner of the box. Connect the end of each line to the vanishing points. Draw the sides of the box with vertical lines. Connect the sides of the box to the opposite vanishing point to create the top/bottom of the box. Erase the rest of the lines to the vanishing point.

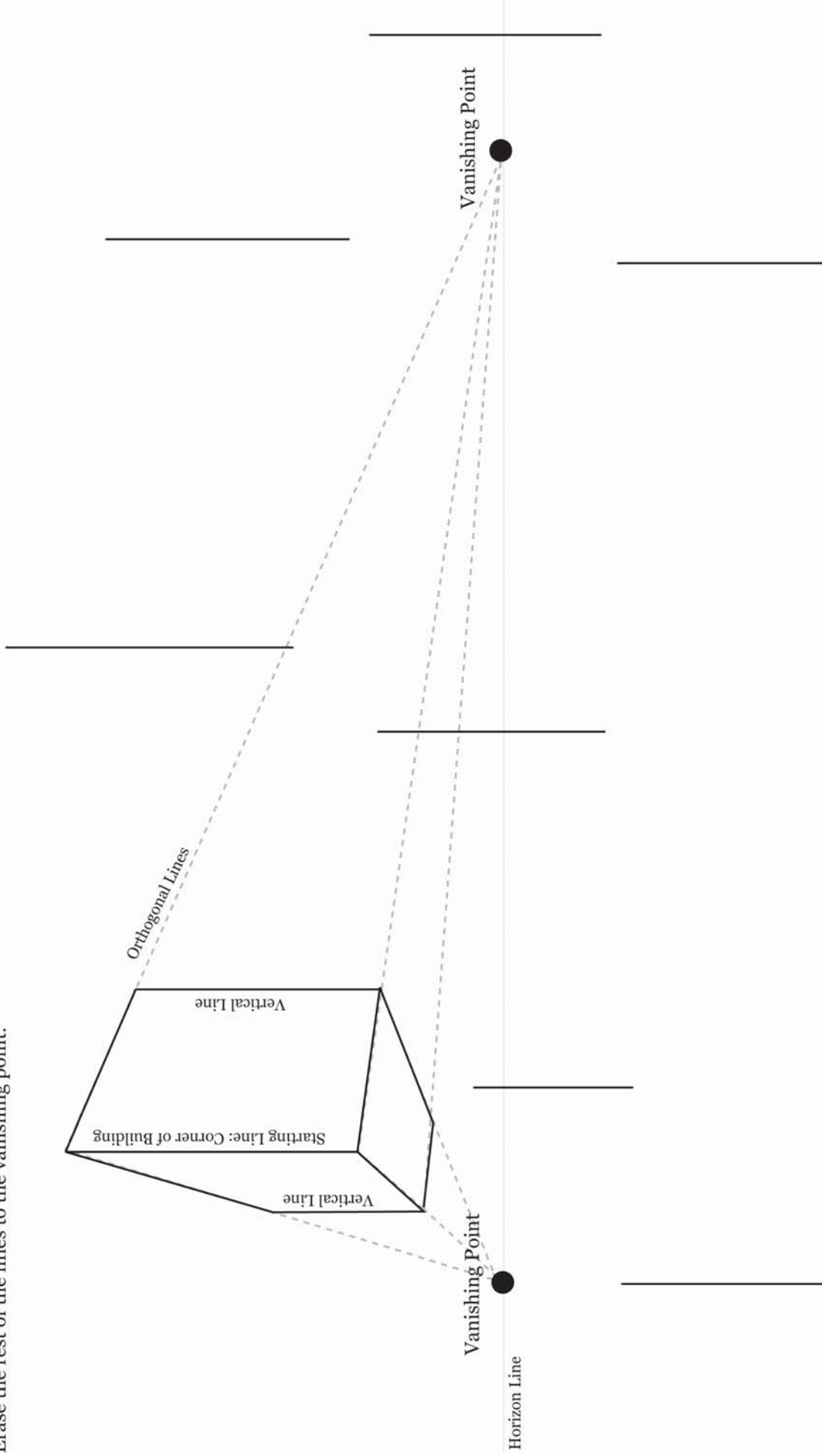

Buildings, Structures and Trucks

Finish drawing each object indicated in two-point perspective.

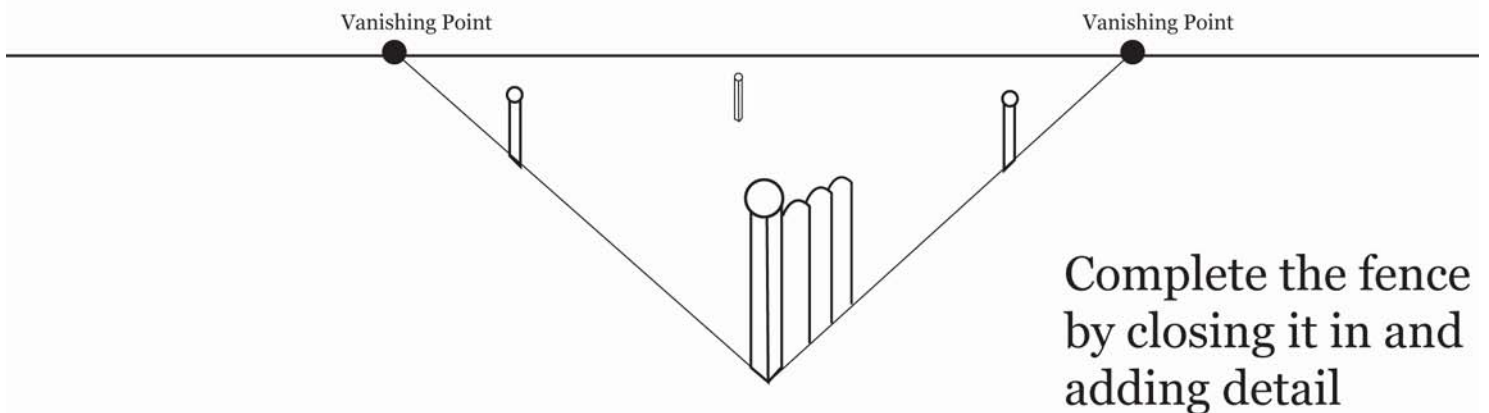
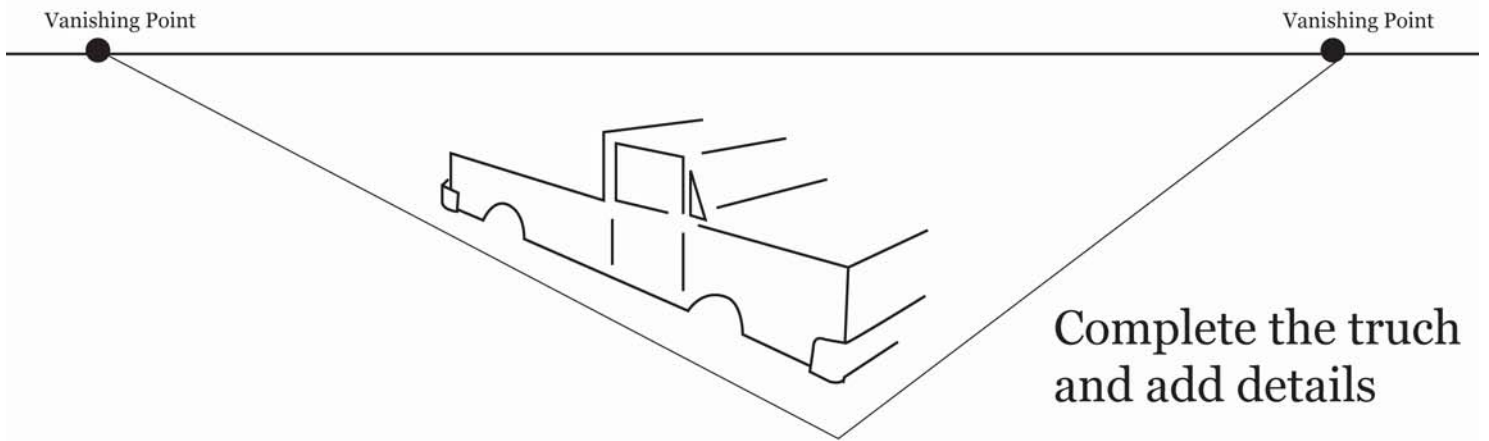
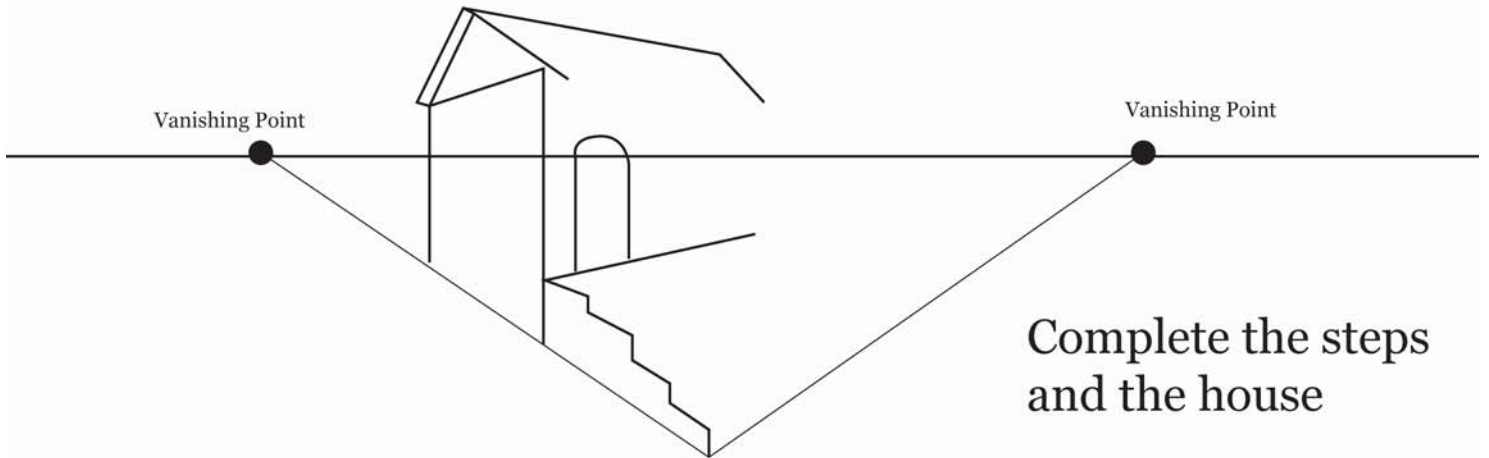

Drawing a City in Two-Point Perspective

Look at the steps for creating a city in tw-point perspective below. On the next page you will create your own fantasy city.

Step 1: Draw a horizon Line



Step 2: Draw two vanishing points



Step 3: Draw a vertical line for the front edge of your building



orthogonal lines

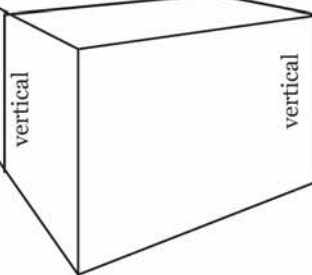

Step 4: Draw orthogonal lines from front edge to vanishing points

Step 5: Draw vertical lines for back edges of the building

Step 6: Connect top corners to opposite vanishing points

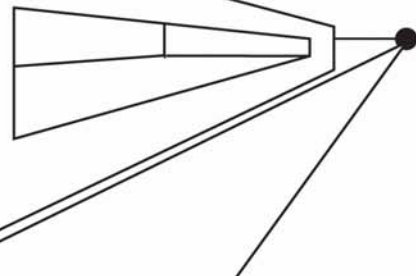
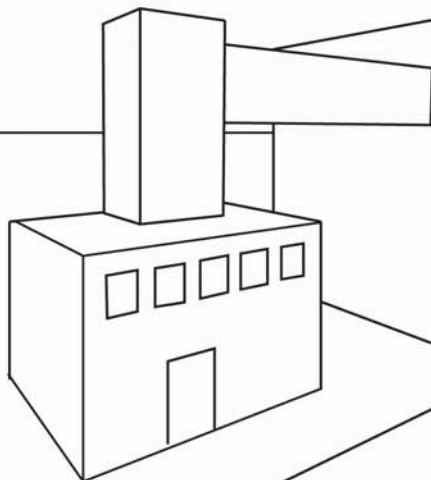
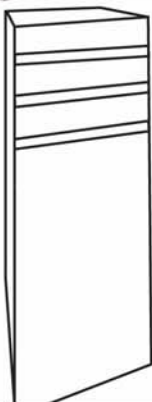

Step 7: Erase unused orthogonal lines

Step 8: Add windows and doors. Add more buildings, try stacking forms, etc.